

ELIXO 800 230V RTS

MOTORIZATION FOR SLIDING GATES



Real-time indication of the product operating status



Motor ground fixation



Up to 10 m
800 kg

Collective housing
Semi-intensive use

Application area

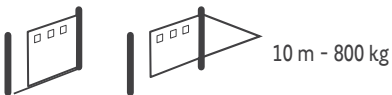

General wiring diagram

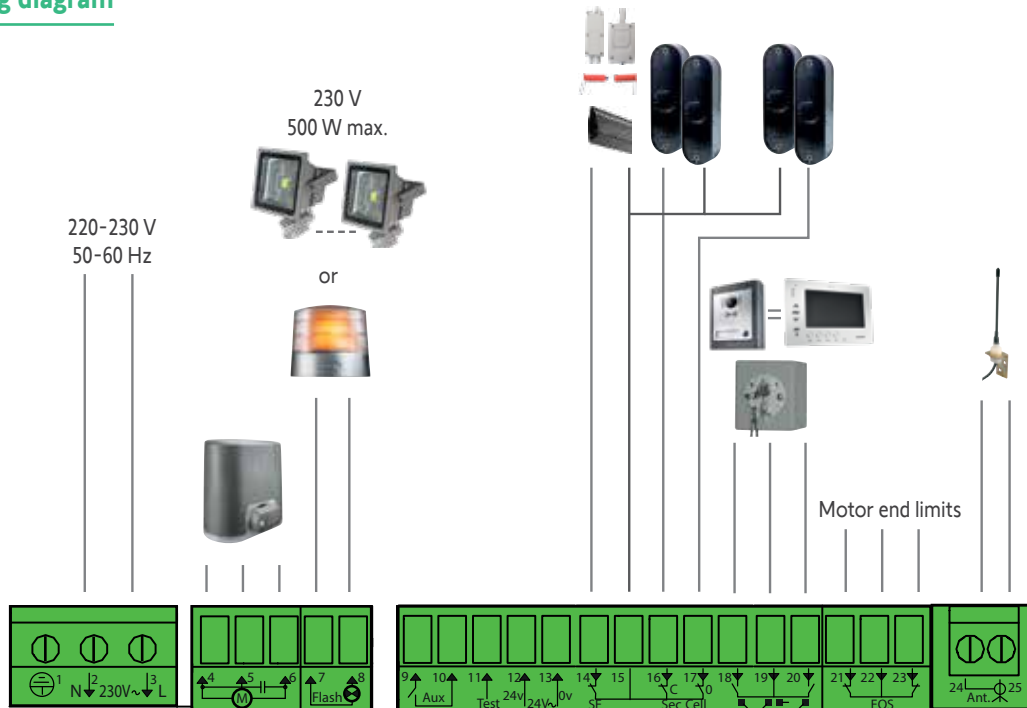

Reliable and hard-wearing for sliding gates

Easy to install

- Easy access to ground fixation screws from the top
- No adjustment needed from the installer

Reliability and durability

- Mechanical design based on 30 years of group experience
- Soft stop

Convenient to use

- Easy and secured declutching with individual key

Gate preserved

- Soft stop and adjustable torque

Easy setting

- One button to learn the gate course
- One button to program remote controls
- 12 switches for advanced settings

Customized and upgradable installation

- Wide range of comfort and security accessories

Easy connection of accessories

- Extractible terminal blocks

Easy maintenance

- Immediate diagnosis: real-time indication of the product operating status

General overall size

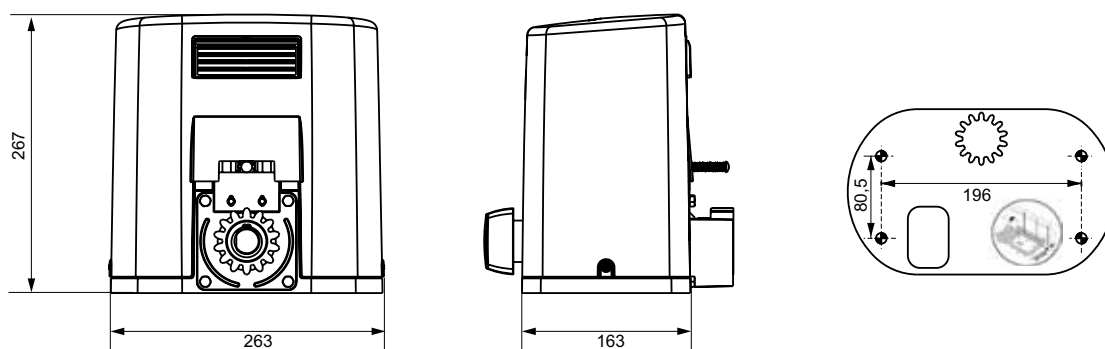

Technical characteristics

Mains power supply	220-230 V - 50-60 Hz
Motor voltage	230 Vac
Maximum power consumption	300 W
Accessories power supply	24 Vac / 315 mA
Opening time to 3 m	21 s

Thrust force	800 N
RTS radio frequency	433.42 MHz
Number of remote controls	128 channels maximum
Index of protection	IP 44
Operating temperature	-20°C to +60°C